

SORRY.
IT CAN'T FLY.

alpha440P – the ultimate upgrade



ALPHA440P PVD COATING SYSTEM

MORE OVERVIEW. MORE COMFORT. MORE PRODUCTIVITY.

The alpha440P PVD coating system is the new generation of the alpha400P. It brings the advantages of its predecessor to your modern production environment. Our new system software and smart sensors enable precise process control and provide detailed information about the system status. Its compact design and high flexibility make it the ideal system to start with or to complement existing systems.

With the coatings available for the alpha440P, it can significantly increase the performance of cutting and forming tools, as well as dental and medical technology products.

TECHNICAL DATA

Usable volume (Ø x H)	450 x 525 mm
Load	Max. 300 kg
Coating chamber (L x W x H)	775 x 700 x 750 mm
Dead weight	3,500 kg
Distributed load	1,060 kg / m ²
Bias	30 kW / max. 1,000 V DC / pulsed DC
Evaporator sources	12 pcs. with each max. 125 A
Batches per day	Up to 5 batches
Exemplary batch endmill (Ø 10 x 70 mm)	432 pcs. per batch
Exemplary batch hobs (Ø 100 x 150 mm)	24 pcs. per batch

ADVANTAGES

- » Advanced sensor/actuator hardware as the basis for predictive maintenance functions
- » High plasma density
- » Optional Fast Cooling System to reduce cooling times by at least 25%.
- » Optional: Duplex-PVD with additional plasma sources for in-situ plasma nitriding
- » Intuitive touch control user interface
- » Easy to maintain
- » Low operation costs
- » Optional: SPCS equipment for access to eifeler's extra smooth and dense ultrafine coatings

STANDARD COATINGS

ARC coatings like:

- » TiN
- » CrCN
- » EXXTRAL®-plus
- » SISTRAL®
- » VARIANTIC®

OPTIONAL COATINGS

ARC coatings like:

- » Duplex coating
- » TiN-ultrafine
- » TiCN-ultrafine
- » SUBLIME®
- » EXXTRAL®-ultrafine
- » SISTRAL®-ultrafine
- » CROSAL®-plus

COMPACT DESIGN

- » All components are accessible through side doors
- » More flexibility in positioning due to small footprint

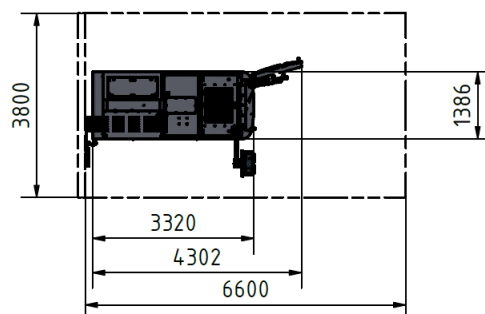

voestalpine eifeler Vacotec GmbH

Hansaallee 321
40549 Düsseldorf, Germany
T. +49 211 522-2440
F. +49 211 522-2480
www.eifeler.com

voestalpine

ONE STEP AHEAD.